

5.0 Megapixel Day/Night High Definition IP Dome Camera

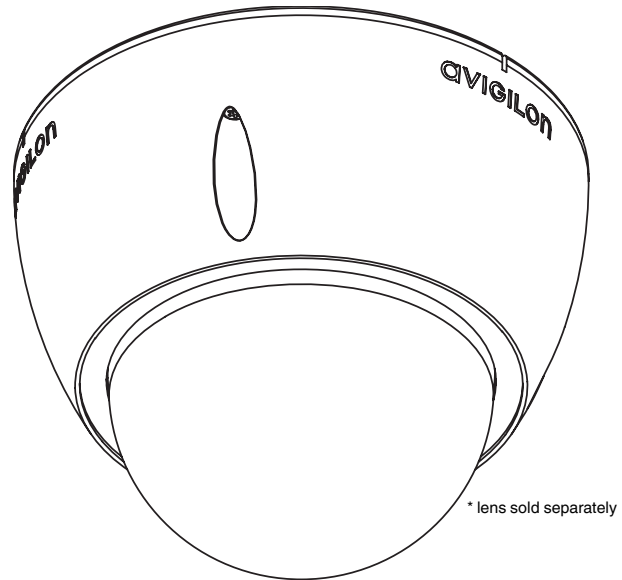

Description

The Avigilon 5.0 megapixel day/night high definition IP dome camera is a progressive scan CMOS camera designed for a wide range of surveillance applications. It transmits images over 100BASE-TX using advanced JPEG2000 progressive compression technology to achieve the lowest network bandwidth and most efficient image storage in the industry while maintaining unsurpassed image quality.

The camera's advanced image acquisition system automatically adjusts the exposure time, the iris and the removable IR cut filter to ensure all available evidence is captured throughout the full range of day and nighttime scenes. The optional short range integrated IR illuminator delivers high resolution surveillance in low-light conditions. The camera supports C or CS mount lenses and DC-drive auto irises and has mounting options for recessed in-ceiling mounting, mounting to an electrical box, and mounting in a sealed IP66-rated outdoor configuration.

The camera seamlessly integrates with Avigilon Control Center NVMS and High Definition NVRs using standard network equipment creating a network based surveillance solution with unmatched performance, ease of use, and ease of installation. Camera power is provided by either Power over Ethernet, 12 VDC, or 24 VAC.

Features

- 5.0 megapixel progressive scan CMOS sensor
- 12 images per second at full resolution and 30 images per second at 1920 x 1080
- 70 dB true dynamic range
- 0.3 lux minimum illumination in color mode and 0.03 lux minimum illumination in monochrome mode
- Lossless JPEG2000 compression
- Automatic exposure control and DC-drive auto iris control
- Automatic removable IR cut filter for IR sensitivity at night with an option for integrated IR illumination
- Compatible with C and CS mount lenses
- Power over Ethernet, 24 VAC or 12 VDC power input
- External I/O interface and an audio input
- Vandal-resistant construction
- IP66 compliant with outdoor mount

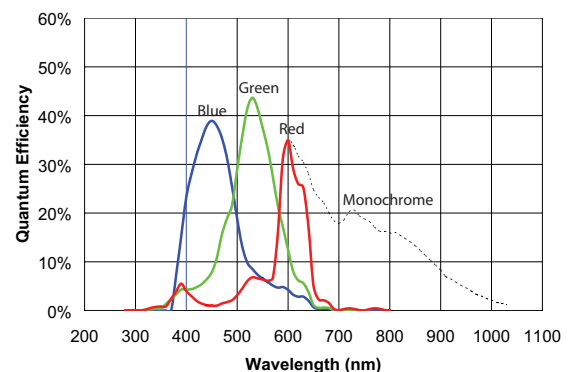

Specifications

Camera

Image Sensor	1/2.5" progressive scan CMOS
Active Pixels	2592 (H) x 1944 (V)
Imaging Area	5.7 mm (H) x 4.3 mm (V) 0.225" (H) x 0.169" (V)
Minimum Illumination	0.3 lux (at F1.4) in color mode 0.03 lux (F1.4) in monochrome mode
Dynamic Range	70 dB
Lens Mount	CS
Image Compression Method	JPEG2000
Image Rate	12 (at full resolution) 30 (at 1920 x 1080)
Resolution Windowing	Down to 640 x 480 Window
Motion Detection	Selectable sensitivity and threshold
Electronic Shutter Control	Automatic, Manual (2 to 1/30000 sec)
Iris Control	Automatic, Manual
Day/Night Control	Automatic, Manual
IR Illuminator (Option)	850 nm wavelength, 15 m (50 ft) range
Flicker Control	50 Hz, 60 Hz
White Balance	Automatic, Manual
Backlight Compensation	Automatic
Privacy Zones	Up to 4 zones
Audio Compression Method	G.711 PCM 8 khz
Audio Input	External 3.5 mm microphone input
External I/O Terminals	Alarm In, Alarm Out, RS-485

Network

Network	100BASE-TX
Cabling Type	CAT5
Connector	RJ-45
Security	SSL
Protocol	UDP, TCP, SOAP, DHCP, Zeroconf

Mechanical

Dimensions (ØxH)	150 mm x 120 mm 5.9" x 4.7"
Weight	0.91 kg (2.0 lbs) without lens
Dome Bubble	Polycarbonate, clear
Body	Aluminum
Housing	Surface mount, vandal resistant
Finish	Powder coat, cool gray 2

Electrical

Power Source	VDC: 12-24 V VAC: 24 V PoE: IEEE802.3af Class 3 compliant
Power Consumption	6 W + 5.5 W with heater option + 3.5 W with IR illuminator option
Power Connector	2-pin terminal block

Environmental

Operating Temperature	-10 °C to +50 °C (14 °F to 122 °F) -30 °C to +50 °C (-22 °F to 122 °F) (with heater option)
Storage Temperature	-10 °C to +70 °C (14 °F to 158 °F)
Humidity	20 - 80% Relative humidity (non-condensing)

Certifications

CE, Class A
FCC, Class A
Meets IP66 standards (with DOME-OD-BASE or DOME-OD-PEND adapter)

Ordering Information

5.0MP-HD-DOME-DN	5.0 Megapixel Day/Night High Definition IP Dome
5.0MP-HD-DOME-DN-H	5.0 Megapixel Day/Night High Definition IP Dome with Heater
5.0MP-HD-DOME-DN-IR	5.0 Megapixel Day/Night High Definition IP Dome with IR Illuminator
5.0MP-HD-DOME-DN-H-IR	5.0 Megapixel Day/Night High Definition IP Dome with Heater and IR Illuminator
DOME-INDE-PLT	Indoor Electrical Box Mounting Plate
DOME-IND-CEL	Indoor In-Ceiling Mount
DOME-OD-BASE	Indoor/Outdoor Mounting Base
DOME-OD-PEND	Indoor/Outdoor Pendant Mount
DOME-SMOKE	Replacement smoked transparent cover.

Outline Dimensions

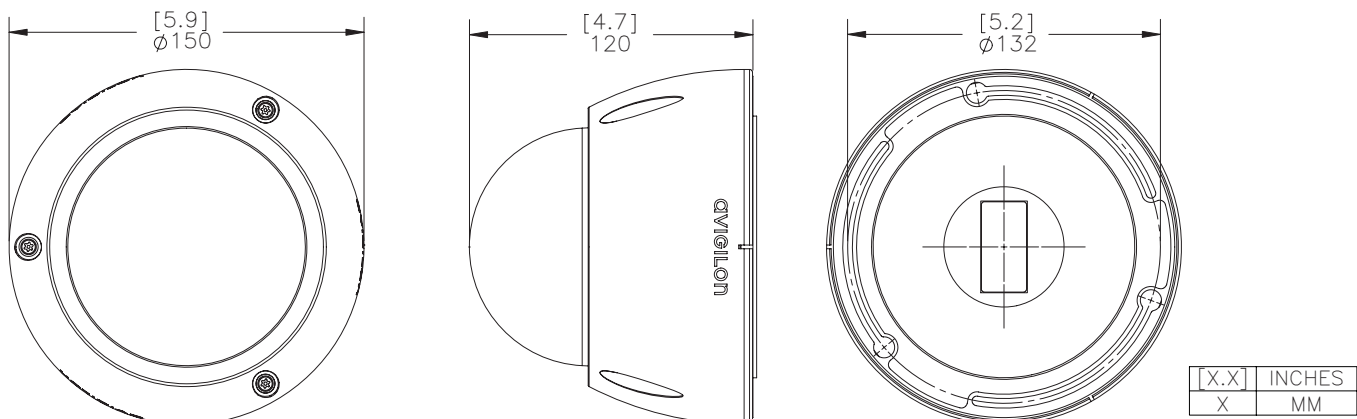

Specifications subject to change without notice. V1.0
©2008 Avigilon Corporation. All rights reserved.